

CHAPTER

2

Surface Area and Volume

You live in a three-dimensional world where ideas such as length, width, and height are not enough for you to understand some objects. To make sense of size in a three-dimensional world, you must understand the concepts of surface area and volume. For example, surface area is used when designing CD inserts for jewel cases. Volume is used when creating PDA, MP3, or cell phone cases.

Big Ideas

When you have completed this chapter you will be able to ...

- solve problems that involve units of area and volume within SI and imperial systems
- solve problems involving surface areas and volumes of spheres, right cones, right cylinders, right rectangular prisms, and right rectangular pyramids
- solve problems involving square roots and cube roots of numbers

Key Terms

surface area
volume
cylinder
prism
lateral area
cone
slant height
sphere
pyramid
apex

Your Measurement Organizer

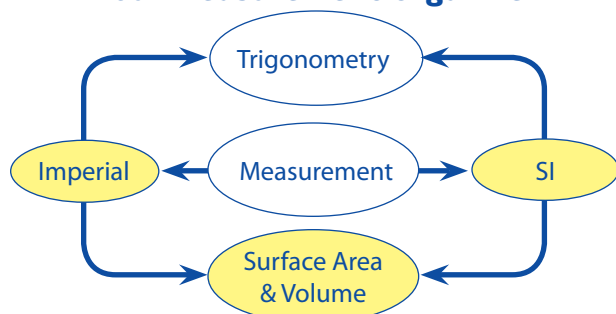

Industrial Designer

Industrial designers are responsible for designing many of the things you see and use every day, from MP3 players to vehicle interiors to electric guitars. In addition to artistic and technical ability, designers often use specialized tools like computer-aided design (CAD) software.



WWW Web Link

If you are interested in learning more about industrial design, go to www.mhrmath10.ca and follow the links.

FOLDABLES Study Tool

Make the following Foldable™ to take notes on what you will learn in Chapter 2.

- ❶ Fold an 11×17 sheet of paper as shown. On the outside front flaps, add the following labels.

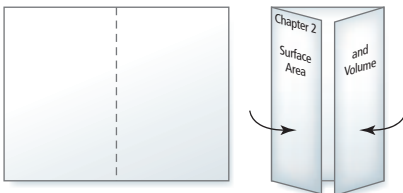

- ❷ Fold and label an 8.5×11 sheet of paper as shown. Cut tabs along the lines on the front half. Attach the tabbed page inside the left flap.

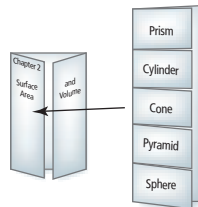

- ❸ Fold and label another 8.5×11 sheet of paper as shown. Cut tabs along the lines on the front half. Attach the tabbed page inside the right flap.

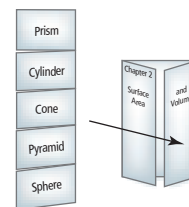

- ❹ On the back of the Foldable™, write the title What I Need to Work On.

2.1

Units of Area and Volume

Focus on ...

- solving problems that involve area and volume units within SI and imperial systems
- using mental math to judge the reasonableness of a solution to a problem

Throughout the history of recorded sound, new technologies have been introduced to replace older ones. One example is the progression from sheet music to vinyl records to cassette tapes to CDs to MP3s. As the music industry has advanced, many outdated products have been abandoned. However, there are many music enthusiasts who still prefer the vinyl record over its digital replacements. They believe that vinyl records have a warmer sound than CDs or MP3s. Vinyl records also feature large album covers with imaginative graphics, pullout photos, and liner notes.



Investigate Units of Area

(Unit Project)

1. By the 1880s, wax cylinders were used to record music. Sound was recorded in the grooves on the outside of hollow cylinders of slightly softened wax. Standard cylinders were about 4 in. long with a diameter of $2\frac{1}{4}$ in. One cylinder could play about two minutes of music or other sound.



- a) Calculate the outside surface area of one of these hollow cylinders.
- b) Calculate the rate of the area needed to record the music to the number of minutes of music.

2. In the 1930s, RCA produced the LP. These vinyl records were pressed on a 30 cm diameter flexible plastic disc. Each LP could hold about 45 min of music using both sides.
- Calculate the circular area of both sides of an LP.
 - Calculate the rate of the area needed to record the music to the number of minutes of music.
3. Records evolved into three sizes and three forms of sound reproduction, the 45 rpm, the 78 rpm, and the $33\frac{1}{3}$ rpm (or LP). Newly pressed records were inserted in a paper or cellophane envelope or sleeve, and then slipped into a printed record jacket or album cover.

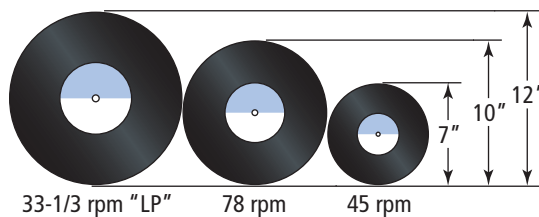

- Choose one size of vinyl record. Calculate the area of a record jacket needed for this vinyl record.
 - Design an album cover that you would use for the record jacket for your favourite recording artist.
4. **Reflect and Respond**
- List possible advantages and disadvantages of vinyl records compared to wax cylinders for recorded music.
 - Vinyl records have recently made a comeback and sales are on the increase. Discuss with a partner some possible reasons for this increase in popularity.
 - Brainstorm other advancements in music storage since the early wax cylinders and discuss how technology has changed the storage of music.

WWW Web Link

To learn more about how vinyl records are made, go to www.mhrmath10.ca and follow the links.

Link the Ideas

Sometimes you may know the dimensions in one measurement system, but need to determine the area or volume in the other measurement system. To work with units of area and volume in both measurement systems, you need to understand the relationships between the units of length in each system. Remember that area involves square units while volume involves cubic units.

Example 1 Convert Between SI Units for Area



Cochrane Mural

An art class is creating a mural mosaic. They know that future art classes will have to contribute to the project to complete it. Each person in the class makes a painting on a 15-cm by 15-cm panel. Then, all the panels are assembled into the mural mosaic. There are 25 students in the art class, so the panels they create will be assembled into a square with each side containing five panels. What area is required for this part of the mural?

Solution

Two students calculate the area required for this part of the mural.

Cassy calculates the area of each individual panel.

$$A = s^2$$

$$A = (15)^2$$

$$A = 225$$

How does Cassy use her knowledge of the area of a square?

Each panel is 225 cm².

There are 25 panels.

$$(25)(225) = 5625$$

The total area is 5625 cm².

Stefan thinks of one large rectangle. Since there are five panels on each side, each measuring 15 cm long, he concludes that each side of the rectangle will measure 75 cm. He converts to 0.75 m and then calculates the area:

$$A = lw$$

$$A = (0.75)(0.75)$$

$$A = 0.5625$$

How does Stefan use his knowledge of the area of a rectangle?

The area is 0.5625 m².

Both students calculated the correct area. When they compared answers, they realized that to convert between square metres and square centimetres, you need to multiply or divide by 10 000.

$$(1 \text{ m})(1 \text{ m}) = 1 \text{ m}^2$$

$$(100 \text{ cm})(100 \text{ cm}) = 10\,000 \text{ cm}^2$$

$$\text{So, } 1 \text{ m}^2 = 10\,000 \text{ cm}^2$$

Recall that there are 100 cm in 1 m.

Your Turn

- Determine the area of a rectangle that is 1.7 m by 2.5 m, in square centimetres.
- Determine the area of a rectangle that is 50 mm by 25 mm, in square metres.

Example 2 Work With Units for Area

Tiles imported from different countries sometimes have imperial dimensions. A tile layer may need to convert from square feet to square centimetres.

One type of floor tiles is sold in squares measuring 1 ft by 1 ft.

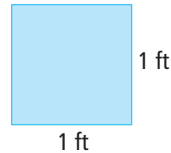

The abbreviation for inches is in. or ".
The abbreviation for feet is ft or '.
The abbreviation for yards is yd.

- a) What is the area of one tile in square centimetres?
- b) The tile layer is working with an area that measures 8 ft by 4 ft. What is the area, to the nearest hundredth of a square centimetre? to the nearest square metre?

Solution

- a) Calculate the area of one tile.

$$A = s^2$$

$$A = (30.48)^2$$

$$A = 929.0304$$

The area of one tile is 929.03 cm^2 , to the nearest hundredth of a square centimetre. You can conclude that 1 ft^2 is approximately 929.03 cm^2 .

Recall that
 $1 \text{ ft} = 30.48 \text{ cm}$.

$1 \text{ ft} \approx 30 \text{ cm}$
A tile that is 1 ft by 1 ft is approximately 30 cm by 30 cm.
 $(30)(30) = 900$
The area of one tile is about 900 cm^2 .

- b) The tile layer needs to convert the dimensions of 8 ft by 4 ft to SI units.

The length is 8 ft.

$$8(30.48) = 243.84$$

Therefore, the length is 243.84 cm.

The width is 4 ft.

$$4(30.48) = 121.92$$

Therefore, the width is 121.92 cm.

$$A = lw$$

$$A = (243.84)(121.92)$$

$$A = 29\,728.9728$$

The tile area is approximately $29\,728.97 \text{ cm}^2$.

Since $100 \text{ cm} = 1 \text{ m}$, then $10\,000 \text{ cm}^2 = 1 \text{ m}^2$.

To express the area in square metres, divide by 10 000.

$$\frac{29\,728.9728}{10\,000} = 2.97289728$$

The tile area is approximately 3 m^2 .

How could you use the value for 8 ft in centimetres to determine the value for 4 ft in centimetres?

Your Turn

- a) Determine the area of a rectangle that is 10 cm by 100 cm, in square feet.
- b) Determine the area of a rectangle that is 6 in. by 4 in., in square millimetres.

Example 3 Work With Units for Volume

Sahid has numerous boxes to load onto a moving truck.

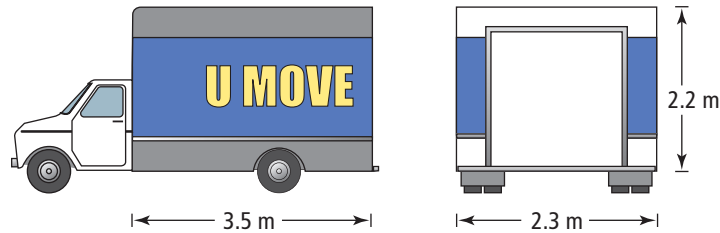

What is the volume of the truck, to the nearest cubic foot?

Solution

Convert the dimensions to feet.

The length is 3.5 m.

$$3.5(3.281) \approx 11.4835 \quad 1 \text{ m} \approx 3.281 \text{ ft}$$

Therefore, the length is approximately 11.4835 ft.

The width is 2.3 m.

$$2.3(3.281) \approx 7.5463$$

Therefore, the width is approximately 7.5463 ft.

The height is 2.2 m.

$$2.2(3.281) \approx 7.2182$$

Therefore, the height is approximately 7.2182 ft.

Find the volume of the truck by using the formula $V = lwh$.

$$V = lwh$$

$$V \approx (11.4835)(7.5463)(7.2182) \quad \text{How does Sahid use his knowledge of the volume of a rectangular prism?}$$

$$V \approx 625.514 \text{ 314}$$

The volume of the truck is approximately 626 ft³.

Your Turn

Convert the volume of an object that measures 3 cm by 4 cm by 10 cm to cubic inches.

$$1 \text{ cm} \approx 0.3937 \text{ in.}$$

Key Ideas

Proportional reasoning can be used to

- solve problems involving area or volume units within SI
- solve problems involving area or volume units within the imperial system
- solve problems requiring the conversion of area or volume within and between the SI and imperial systems using linear dimensions

Convert 0.62 m^2 to square centimetres.

$$1 \text{ m} = 100 \text{ cm}$$

$$1 \text{ m}^2 = (100 \text{ cm})(100 \text{ cm}) \\ = 10\,000 \text{ cm}^2$$

$$0.62 \text{ m}^2 = (0.62)(10\,000 \text{ cm}^2) \\ = 6200 \text{ cm}^2$$

0.62 m^2 is equal to 6200 cm^2 .

Calculate the volume of a rectangular prism with dimensions 1 ft by 3 ft by 5 ft in cubic metres.

$$1 \text{ ft} = 0.3048 \text{ m} \quad 3 \text{ ft} = 3(0.3048 \text{ m}) \quad 5 \text{ ft} = 5(0.3048 \text{ m}) \\ = 0.9144 \text{ m} \quad = 1.524 \text{ m}$$

$$V = (0.3048 \text{ m})(0.9144 \text{ m})(1.524 \text{ m})$$

$$V = 0.4247526989 \text{ m}^3$$

The volume of the prism is approximately 0.42 m^3 .

Check Your Understanding

Practise

For help with #1 and #2, you may need to refer to the table of conversion factors.

Imperial Unit	SI Unit
1 in.	2.54 cm
1 ft	0.3048 m
1 yd	0.9144 m
1 mi	1.609 km

1. Calculate the following areas to the indicated SI unit. Express your answers to the nearest tenth of a square unit.

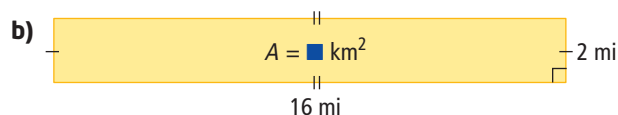
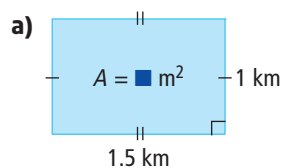

- c) the area of a rectangle 35 in. by 10 in., in square centimetres
- d) the area of a rectangle 21 ft by 50 ft, in square metres

2. Determine possible dimensions for each area. Then, use your dimensions to calculate the area to the indicated equivalent.

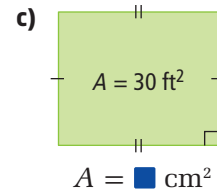
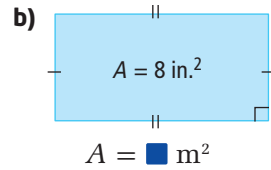
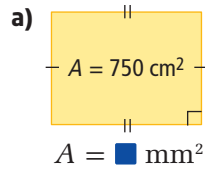

Did You Know?

The *Festival du Voyageur* was founded in 1969 by a group of Saint-Boniface entrepreneurs. Originally a 3-day event held in Winnipeg's French Quarter, this event has evolved into a 10-day province-wide celebration. The *Festival du Voyageur* celebrates the *joie de vivre* of the fur traders, who established the Red River Colony and the growing French-Canadian community in western Canada. Held every February, the *Festival du Voyageur's* emphasis is on the beauty of winter, with numerous historical, educational, and entertaining activities.

3. At the *Festival du Voyageur*, an outdoor winter beaverball court is being built. The court measures 9 m by 18 m. Your task as a volunteer is to cover it with a tarp. You find that tarps are sold by the square yard. Find the area required for the tarp in square yards.



Festival du Voyageur, Winnipeg

4. For each of the following containers, find the volume in cubic centimetres.

- a) a cube with sides measuring 6 in.

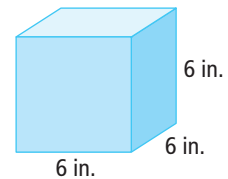

- b) a right rectangular prism with sides measuring 12 in. by 8 in. by 25 in.

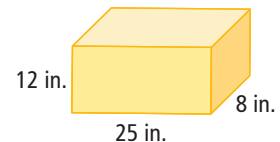

5. A pickup truck has a box that measures 4 ft by 8 ft by 17 in. What is the volume of the box to the nearest tenth of a cubic metre?

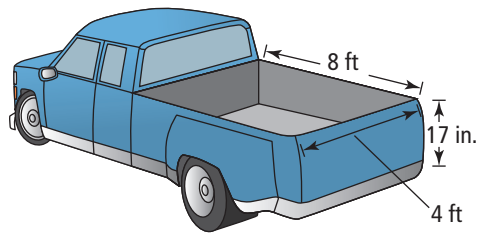

Apply

6. The *Quilt of Belonging* is a project created by artist Esther Bryan. The quilt includes 263 handmade, 11-in.-square blocks, representing each immigrant, First Nation, Métis, and Inuit group in Canada. Seventy of these blocks each represent a First Nation, Métis, or Inuit group in Canada. What is the total area of these 70 blocks, in square feet and in square metres?



Did You Know?

The *Quilt of Belonging* is "... the largest and most inclusive work of textile art made about Canada." Esther Bryan, the project artist, says, "The completed quilt, with its many parts, shows that we all can be integrated into the fabric of Canada, living together harmoniously, learning to respect one another for our differences while celebrating what we have in common."

7. Gentry's family is buying a new home. Gentry is concerned about the size of his bedroom in the new home. Gentry's current bedroom measures 10'6" by 11'3". The floor plan shows that his new bedroom would have an area of 11.4 m².
- Which room is bigger? by what percent?
 - The carpet in Gentry's new bedroom is worn and needs to be replaced. He finds new carpet he likes for \$12.99 per square yard. What is the cost of the new carpet for Gentry's new room, before tax?
8. Andrea is preparing an installation manual for a cell-phone tower to be used in a European country. The tower specifications are in imperial units, and she must convert them to SI for her client. The specifications state that the signal for the cell-phone tower covers a circular area of radius 2.5 mi. What is this area in SI units?

9. A tile layer has an entranceway to tile. The entrance measures $5'2''$ by $3'6''$. The tiles each measure $4''$ by $4''$.
- What is the area of the entranceway, in square inches?
 - When working on tiling projects, it is recommended that the installer purchase 10% extra material. How many tiles should be purchased for this project?
10. At the local recreation centre, you have a choice between two different types of lockers. You can choose a single locker from a double stack, or a single locker from a triple stack. The dimensions of each stack of lockers are shown below.

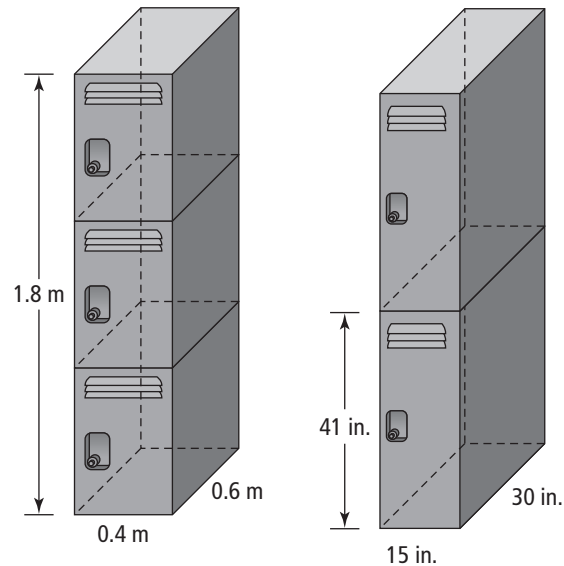

- Which type of locker would give you more space?
 - How much more space, in cubic metres, would you have?
11. Describe how you would determine each volume in the indicated units. What is the volume?
- a cube with dimensions 1 m by 1 m by 1 m in cubic centimetres
 - a rectangular prism with dimensions 5 cm by 7.1 cm by 10 cm in cubic metres
 - a rectangular prism with dimensions 0.5 m by 1 m by 5 m in cubic millimetres

Extend

12. In the imperial system, large areas of land are measured in acres. For example, the area of Shaw Millennium Skate Park in Calgary, the biggest public skate park in North America, is about 1.85 acres.
- One acre is the same as 43 560 ft². What is the area of Shaw Millennium Skate Park in square feet?
 - Show how you would determine the area you found in part a) in square metres.
 - The SI unit for large areas is the hectare. One hectare is the same as 10 000 m². Express the area of Shaw Millennium Park in hectares.
13. The maps in an atlas use scale diagrams. Choose a rectangular area on a map of northern Canada. Using the scale from the atlas, calculate the area of your rectangle in square miles and in square kilometres.

Create Connections

14. What occupations do you think would use both the imperial and SI measurement systems?
15. Describe your preferred method for converting between SI and imperial measures. Why did you choose this method?
16. Think of your local grocery store. In which departments of the store would you need measurement conversions? Explain.



Shaw Millennium Skate Park,
Calgary



2.2

Surface Area



Blackfoot Crossing Exhibit Hall

Focus on ...

- solving problems involving the surface area of three-dimensional objects
- finding an unknown dimension of a three-dimensional object given its surface area

Architectural design ideas may evolve from your culture, icons, or everyday life. The exhibit hall at the Blackfoot Crossing Historical Park in southern Alberta is a cultural, educational, and entertainment centre built at the site of the signing of Treaty 7.

The knowledge of surface area of integrated structures is essential when constructing architectural designs like the Blackfoot Exhibit Hall. Architects use surface area to calculate the amount of material needed.

Investigate Surface Area of Three-Dimensional Objects

1. As a group, divide a sheet of paper into four quadrants. Label the quadrants with the following:

Quadrant 1: Group Definition of Surface Area

Quadrant 2: Group Strategy for Determining Surface Area

Quadrant 3: Determine Surface Area

Quadrant 4: Alternative Method for Determining Surface Area

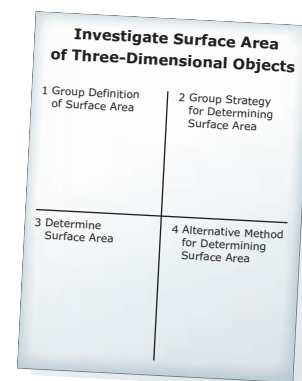

2. As a group, choose one of the three-dimensional objects shown below.

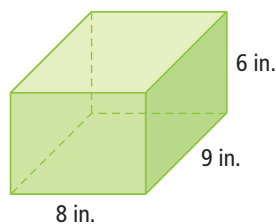
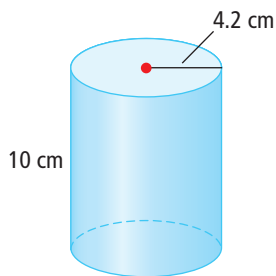

Complete quadrant 1 and one of the three remaining quadrants. Then, pass the sheet on to another group.

3. a) Review and discuss the work of the other groups.
b) Choose and complete one of the remaining quadrants. Then, pass the sheet of paper on to another group.
4. Repeat the process in step 3 for the remaining quadrant.
5. **Reflect and Respond**
- a) Did another group's strategy work better than yours? Why or why not?
b) Did you see any alternative strategies that you preferred? Explain.
c) In quadrant 3, was there a group strategy that you preferred? Explain.
6. Consider the ideas you discussed in step 5. Suggest possible strategies you could use to determine the surface area of each of the following 3-D objects.
- a) cone
b) sphere
c) pyramid

WWW Web Link

To learn more about Blackfoot Crossing Historical Park, go to www.mhrmath10.ca and follow the links.

Eagle feather fan over the entrance to Blackfoot Exhibit Hall

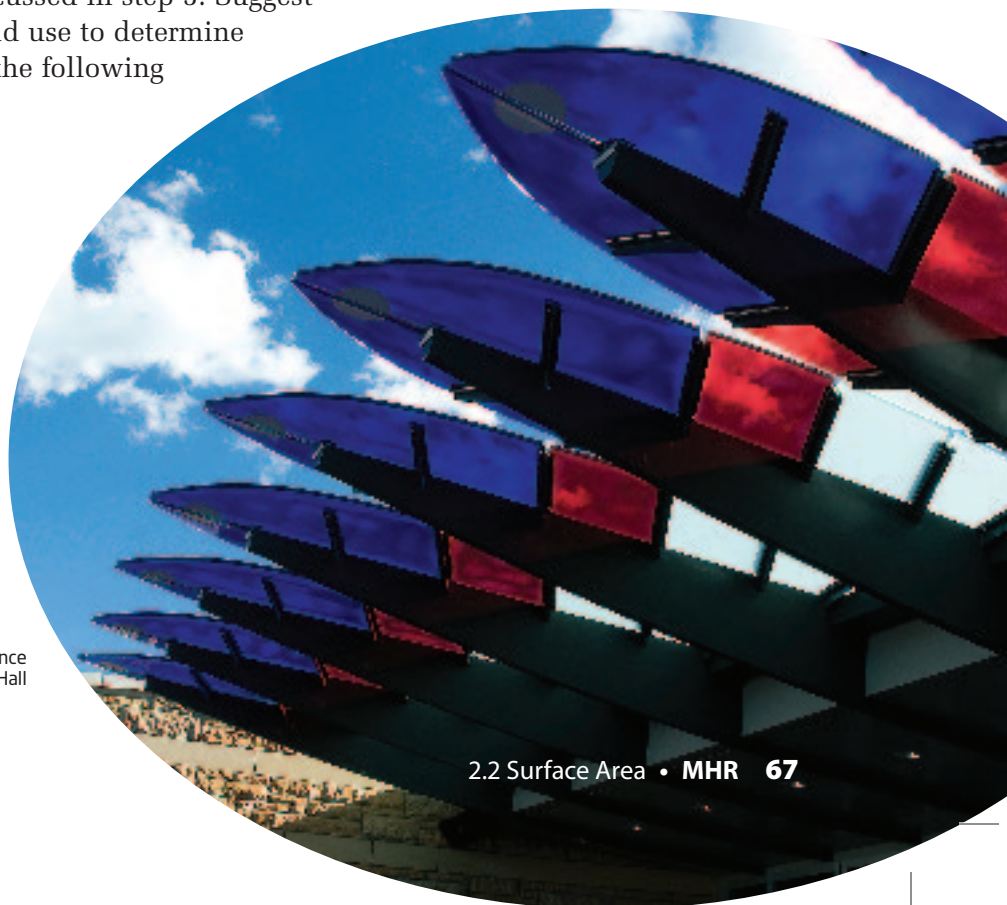

cone

- a three-dimensional object with a circular base and a curved lateral surface that extends from the base to the vertex

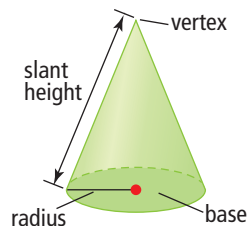

slant height

- the shortest lateral distance from the edge of the base of a cone or pyramid to its highest point

lateral area

- the surface that joins the two bases of a three-dimensional object or that joins the base to the highest point

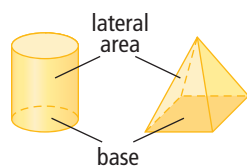

Link the Ideas

Surface Area of a Right Cone

Consider a right cone with slant height s and base radius r . Construct a net of the cone, including the lateral area and the base.

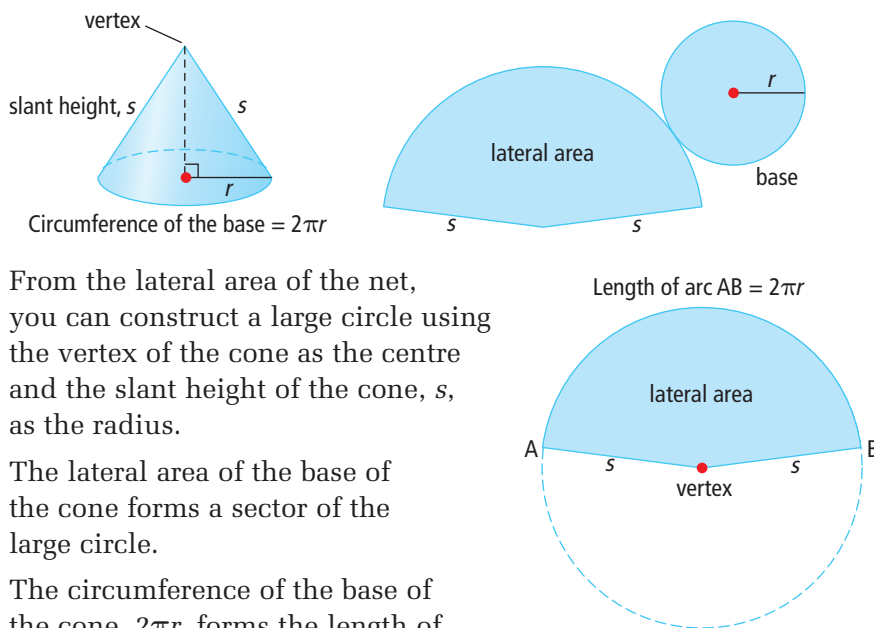

From the lateral area of the net, you can construct a large circle using the vertex of the cone as the centre and the slant height of the cone, s , as the radius.

The lateral area of the base of the cone forms a sector of the large circle.

The circumference of the base of the cone, $2\pi r$, forms the length of the arc AB of the sector.

The circumference of the large circle that is formed from the lateral area is $2\pi s$.

The area of the large circle is πs^2 .

To determine the lateral area of the cone you can set up a proportion of corresponding ratios.

$$\frac{\text{lateral area of cone}}{\text{area of large circle}} = \frac{\text{circumference of cone}}{\text{circumference of large circle}}$$

$$\frac{\text{lateral area of cone}}{\pi s^2} = \frac{2\pi r}{2\pi s}$$

$$\frac{\text{lateral area of cone}}{\pi s^2} = \frac{r}{s}$$

$$\text{Lateral area of cone} = \left(\frac{r}{s}\right)(\pi s^2)$$

$$\text{Lateral area of cone} = \pi rs$$

The lateral area of a right cone with radius r and slant height s is πrs .

The base of the cone is a circle with radius r , so its area is πr^2 .

The total surface area of a right cone is the sum of the areas of the base and the lateral surface.

$$SA_{\text{cone}} = \pi r^2 + \pi rs$$

Surface Area of a Sphere

The formula for the surface area of a **sphere** is linked to the surface area of a right cylinder. Think of wrapping a right cylinder around the sphere.

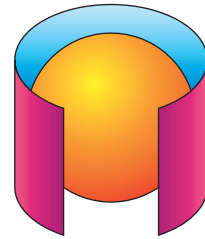

The diameter of the sphere will be the height of the cylinder.

This height will be $2r$.

The circumference of the sphere will be the circumference of the cylinder. This circumference will be $2\pi r$.

The lateral area of the cylinder, when flattened, forms a rectangle. The area of the rectangle formed by the right cylinder is directly related to the surface area of the sphere.

$$A = (\text{length})(\text{width})$$

$$A = (2\pi r)(2r)$$

$$A = 4\pi r^2$$

$$SA_{\text{sphere}} = 4\pi r^2$$

sphere

- a round, ball-shaped object
- a set of points in space that are a given distance (radius) from a fixed point (centre)

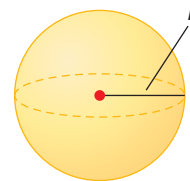

Example 1 Calculate the Surface Area of a Right Cone

A right cone has a circular base with diameter 27 cm and slant height 40 cm. Calculate the surface area of the cone, to the nearest tenth of a square centimetre.

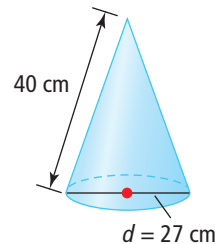

Solution

The surface area of a right cone is the sum of the area of the single circular base, B , and the lateral area.

$$SA = B + \text{lateral area}$$

$$SA = \pi r^2 + \pi rs$$

$$SA = \pi(13.5)^2 + \pi(13.5)(40)$$

$$SA = 2269.015\dots$$

Since the diameter of the circle is 27 cm, the radius is 13.5 cm.

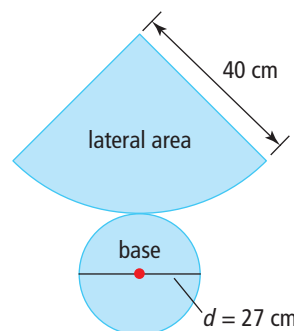

The surface area of the cone is approximately 2269.0 cm^2 .

Your Turn

Sketch a right cone with diameter 16 cm and slant height 12 cm. What is its surface area?

pyramid

- A three-dimensional object with one base and the same number of triangular faces as there are sides on the base

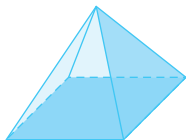

Example 2 Calculate the Surface Area of a Right Pyramid

A right rectangular **pyramid** has a rectangular base measuring 16 cm by 20 cm. The slant height of the triangular face with the shorter base is 18 cm, while the slant height of the triangular face with the longer base is 17 cm. What is the surface area of the pyramid?

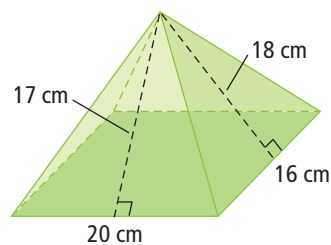

Solution

As with a right cone, the surface area of a right pyramid can be calculated as the sum of the area of the base, B , and the lateral area.

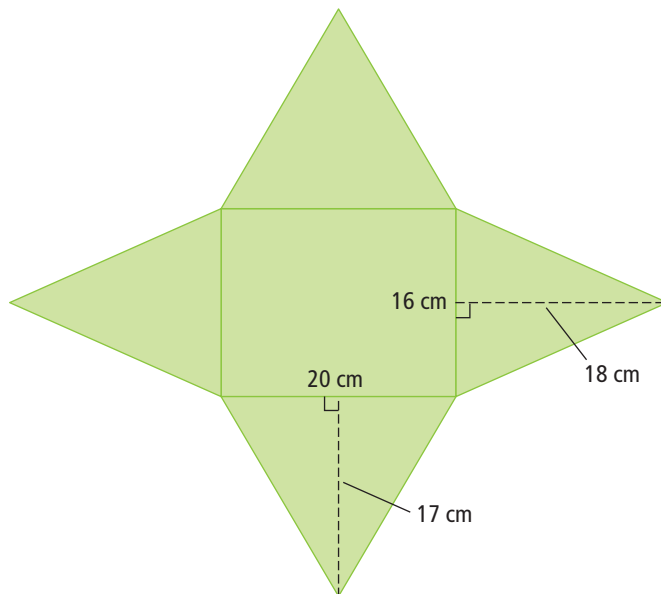

$$SA = B + \text{lateral area}$$

$$SA = (\text{length})(\text{width}) + 2\left[\frac{1}{2}(\text{length})(\text{slant height}_1)\right] + 2\left[\frac{1}{2}(\text{width})(\text{slant height}_2)\right]$$

$$SA = (20)(16) + 2[0.5(20)(17)] + 2[0.5(16)(18)]$$

$$SA = 948$$

The surface area of the right rectangular pyramid is 948 cm^2 .

The lateral area of a right rectangular pyramid is made up of four triangles. The triangles on the opposite faces are the same size.

Your Turn

Sketch a right rectangular pyramid with a square base measuring 10 cm on each side. The slant height of each face is 8.5 cm. What is the surface area of the pyramid?

Example 3 Calculate the Surface Area of a Sphere

A satellite is wrapped with polyester film to protect it during transportation. How much film is required to cover the Echo Satellite, which has a circumference of 95.8 m? Express your answer to the nearest tenth of a square metre.

Solution

The formula for the surface area of a sphere is $SA = 4\pi r^2$, where r is the radius. Calculate the radius from the circumference.

$$C = 2\pi r$$

$$95.8 = 2\pi r$$

$$r = \frac{95.8}{2\pi}$$

$$r = 15.247\dots$$

Substitute the radius into the formula for the surface area.

$$SA = 4\pi r^2$$

$$SA = 4\pi(15.247\dots)^2$$

$$SA = 2921.333\dots$$

Approximately 2921.3 m² of film is required to cover the satellite.

Your Turn

Find the surface area of a basketball with diameter 23.85 cm. Express your answer to the nearest hundredth of a square centimetre.

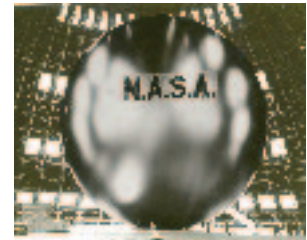

Example 4 Determine a Dimension When the Surface Area is Known

The surface area of an official 5-pin bowling ball varies from approximately 459.96 cm² to 506.71 cm². What is the variation in the diameter of the bowling ball?

Solution

Substitute into $SA = 4\pi r^2$.

$$4\pi r^2 = SA$$

$$4\pi r^2 = SA$$

$$4\pi r^2 = 459.96$$

$$4\pi r^2 = 506.71$$

$$r^2 = \frac{459.96}{4\pi}$$

$$r^2 = \frac{506.71}{4\pi}$$

$$r = \sqrt{\frac{459.96}{4\pi}}$$

$$r = \sqrt{\frac{506.71}{4\pi}}$$

$$r \approx 6.05$$

$$r \approx 6.35$$

How do you calculate the diameter from the radius?

The variation in the diameter of an official 5-pin bowling ball is from 12.1 cm to 12.7 cm.

Your Turn

To the nearest millimetre, calculate the radius of a sphere with a surface area of 1 m².



Did You Know?

Artifacts from a game similar to bowling were found in the tomb of an ancient Egyptian youth who died in approximately 5200 B.C.E. Ancient Polynesians rolled stones at objects from a distance of 60 ft (18.29 m). This is the same distance as from the foul line to the headpin in modern-day bowling.

Example 5 Visualize and Find Surface Areas of Composite Objects

A farm equipment manufacturer in Yorkton, SK, has decided to construct a grain bin using galvanized steel. How much steel is required to construct the grain bin as shown? Express your answer to the nearest hundredth of a square foot. Do not include overlap of the steel sheets where they are fastened together.

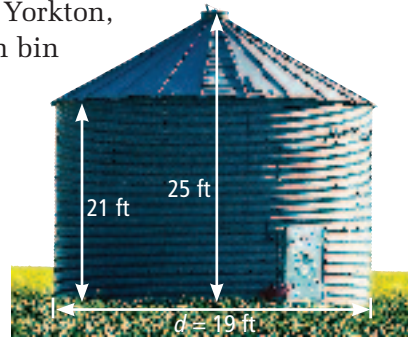

Solution

Visualize the cylindrical base with a right cone-shaped roof. Sketch the two parts of the structure and add appropriate dimensions.

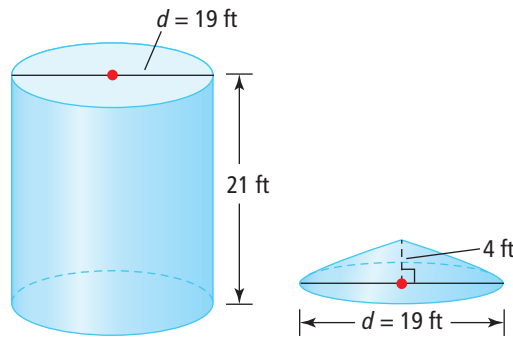

Remember that the bottom and top of the cylindrical portion and the bottom of the conical roof are not included.

surface area of cylindrical shape = $\pi d \times \text{height}$

$$SA_{\text{cylinder}} = \pi(19)(21)$$

$$SA_{\text{cylinder}} = 1253.495\dots$$

The circumference of a circle can be found using the formula πd or $2\pi r$.

To calculate the surface area of the cone, you need to know the slant height first.

Use the Pythagorean relationship.

$$s = \sqrt{4^2 + 9.5^2}$$

$$s = \sqrt{16 + 90.25}$$

$$s = \sqrt{106.25}$$

$$s = 10.307\dots$$

surface area of conical shape = πrs

$$SA_{\text{cone}} = \pi(9.5)(10.307\dots)$$

$$SA_{\text{cone}} = 307.636\dots$$

The combined surface area is $1253.495\dots + 307.636\dots = 1561.132\dots$

The total surface area of the grain bin, to the nearest hundredth of a square foot, is 1561.13 ft^2 .

You will need a minimum of 1562 ft^2 of galvanized steel to construct the grain bin.

Your Turn

Calculate the surface area of the following composite object, to the nearest tenth of a square centimetre.

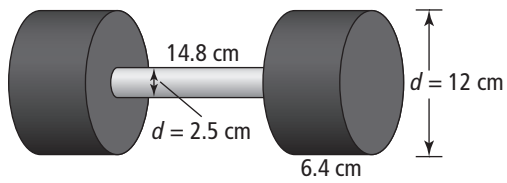

Key Ideas

- The surface area of a right cylinder and of a right prism can be calculated using the area of the bases (top and bottom) plus the lateral area.

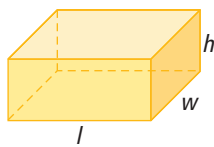

$$SA_{\text{prism}} = 2lw + 2lh + 2wh$$

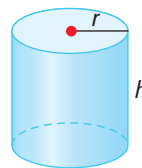

$$SA_{\text{cylinder}} = 2(\pi r^2) + 2\pi rh$$

- The surface area of a right pyramid and of a right cone can be calculated using the area of the base plus the lateral area.

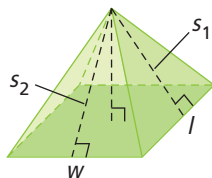

$$SA_{\text{pyramid}} = lw + 2\left[\frac{1}{2}ls_1\right] + 2\left[\frac{1}{2}ws_2\right]$$

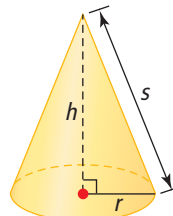

$$SA_{\text{cone}} = \pi r^2 + \pi rs$$

- The surface area of a sphere depends on the radius only.

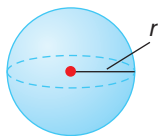

$$SA_{\text{sphere}} = 4\pi r^2$$

Check Your Understanding

Practise

For each of the following, express your answers to the nearest tenth of a unit where necessary.

1. Calculate the surface area of each of the following.

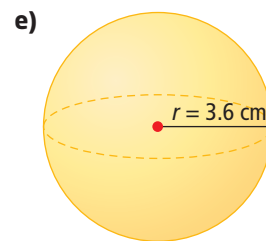
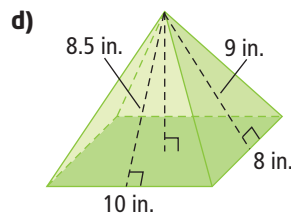
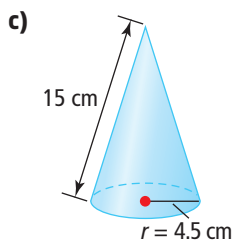
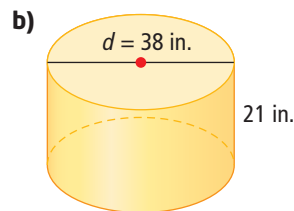
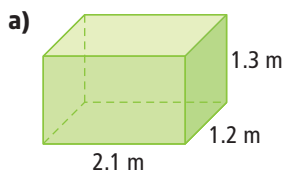

2. Sketch a right pyramid with a square base measuring 16 ft by 16 ft. The slant height is 12 ft. What is the surface area of the pyramid?
3. For each of the following, the surface area is given. Calculate the missing dimension.

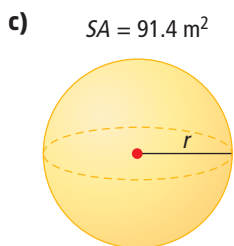
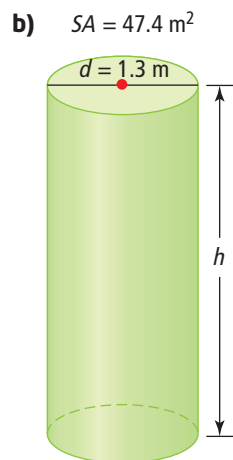
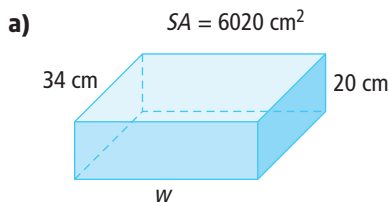

4. A closed box has a surface area of 126 in.^2 . The base of the box is 5 in. by 3 in. Sketch a diagram and find the height of the box.

5. Calculate the surface area of this object composed of a pyramid and a sphere.

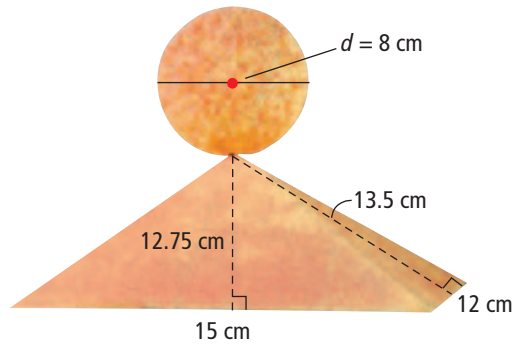

Apply

6. Austin is helping to build the set for a school play. There are four cylindrical pillars standing on the stage that need to be painted. Each pillar is 16 ft high and 1 ft in diameter, as shown below. Austin calculated the surface area to the nearest hundredth of a square foot. His work is shown below.

$$SA = 2(\pi r^2) + \pi d(h)$$

$$SA = 2(\pi)(0.5)^2 + \pi(1)(16)$$

$$SA = 0.5\pi + 16\pi$$

$$SA = 16.5\pi$$

$$SA \approx 51.84$$

There are four cylinders, so

$$SA = 4 \times 51.84$$

$$SA = 207.36$$

The surface area is 207.36 ft².

Austin thinks he made an error in his work. Discuss whether Austin actually made an error. What surface area would you paint?

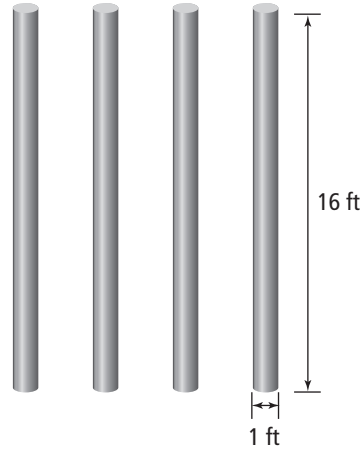

7. One of the activities available to visitors to the Blackfoot Crossing Historical Park is to spend the night in a tipi. Historically, the walls and floor of a tipi were made of buffalo hide, but the current tipi is canvas with a large circular fabric floor. At the beginning of the season, the staff of the park set up the tipis. While doing so, they determine that the diameter of a tipi is 9.6 m and its slant height is 7.3 m. Assume that the tipi approximates a cone. What is the minimum amount of canvas making up the sides of the tipi, to the nearest hundredth of a square metre? Do not include any seam allowances.

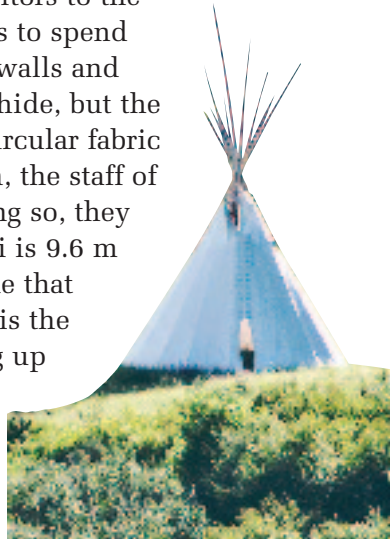

8. **Unit Project** Compact discs are sometimes packaged in cylindrical stacks of 100. Each CD has a thickness of 1.2 mm and a diameter of 12 cm.

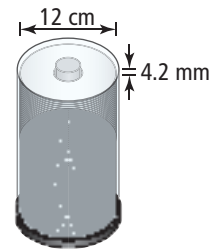

- a) The outside radius of the storage case is 0.7 cm more than that of the CD. The height of the case is 4.2 mm more than that of the stack of 100 CDs. What is the surface area of the storage case, excluding the base, to the nearest square centimetre?
- b) If a rectangular CD jewel case holding a single CD is 0.5 cm wider than the CD, 2.5 cm longer than the CD, and 8 times the thickness of the CD, what is the surface area of the jewel case?

9. A designer is working on a line of athletic equipment. He is designing a cylindrical punching bag, similar to the one shown. The designer wants to use a maximum of 1.3 m^2 of material to make the bag, and has determined that the diameter of the bag should be 36 cm. Determine the maximum possible height of the bag, to the nearest tenth of a centimetre.



10. Earth has a diameter of approximately 8000 mi. Land forms about 29% of the surface area of Earth. Assume Earth is a sphere. Estimate the area of land on Earth.



11. The photo shows a traditional Haida hand drum that has a diameter of $14\frac{7}{8}$ in. and is 3 in. deep. What is the minimum amount of hide used to make the drum if the hide covers only the top and lateral surfaces? Express your answer to the nearest square inch.



Traditional Haida hand drum showing twin salmon transforming into the next generation. Traditional Haida hand drums are used in ceremony, cultural events such as potlatches, and as artwork. Traditional drums should always be handled with respect following appropriate protocol.

12. The Muttart Conservatory in Edmonton began with a donation from the Muttart family. There are four greenhouses, each in the shape of a right pyramid with a square base. Each of the two largest greenhouses has a base that measures 26 m on each side and has a slant height of 35.4 m. How much glass is needed for each large greenhouse? Express your answer to the nearest square metre.

13. What is the surface area of a glass bead that has a diameter of 11 mm? Express your answer to the nearest square millimetre.

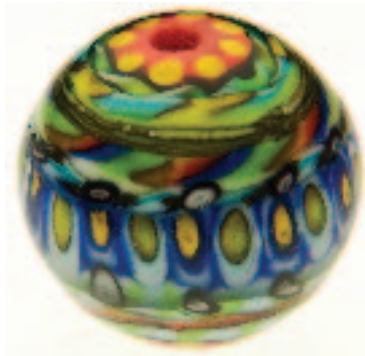

14. Photographers often use a light tent to get the best lighting for items they photograph for museums, catalogues, or online sales. This tent is cylindrical with a conical roof. The diameter of the tent is 1 m, the height of the tent is 190 cm, and the cylindrical wall of the tent is 135 cm high. What is the surface area of the light tent, to the nearest square metre?



Did You Know?

Around the year 1148, the French played *le paume*, meaning “the palm of the hand.” This game developed into *jeu de paume*, *real tennis*, *royal tennis*, or, simply *tennis*.

15. Squash is a racquet sport played with a small, soft ball. The game is named for the fact that it is very easy to “squash” the ball. The rules of the game state that the ball must have a diameter of $40 \text{ mm} \pm 0.5 \text{ mm}$. This means that the actual diameter can be up to 0.5 mm more or less than 40 mm.



- a) What is the minimum and maximum surface area of a regulation squash ball? Express your answers to the nearest square millimetre.
- b) Squash balls are often packaged in cubical boxes as shown in the photo. If the box is to be sized so that the ball fits exactly in the box, find the minimum and maximum dimensions of the box.

Extend

For each of the following, express your answers to the nearest tenth of a unit where necessary.

16. Gas stations often have a supply of small paper funnels that customers can use to add oil to their vehicle engines without spilling. Each funnel is a right cone with a small hole cut out of the top. The funnel has a slant height of 13.2 cm and the diameter of the large opening is 9.5 cm. The diameter of the small opening is 1.5 cm. Determine the amount of paper in the funnel.

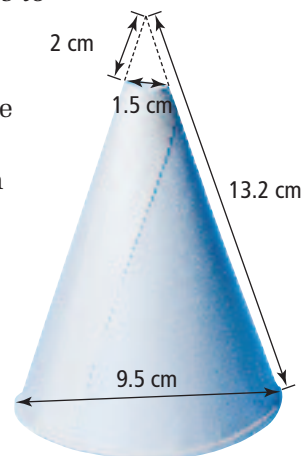

17. A building block is shown below.

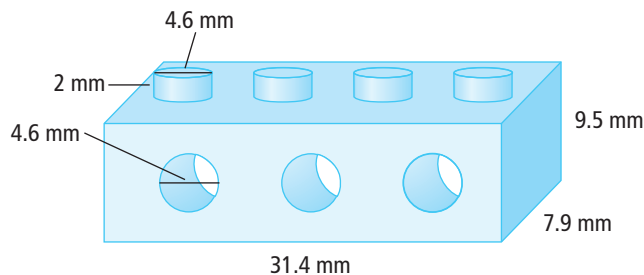

The base of the block measures 31.4 mm by 7.9 mm, and it has a height of 9.5 mm. Each right cylinder on top of the block has a diameter of 4.6 mm and a height of 2 mm. Each hole in the block has a diameter of 4.6 mm. Determine the surface area of the block that needs to be painted if you do not paint the bottom of the block.

18. Use spreadsheet software to help investigate how changing the radius of a sphere changes its surface area. Create a spreadsheet like the one shown below.

	A	B	C	D
1	Investigating Changes in Dimensions of a Sphere			
2	Stretch Factor	Radius	Surface Area	Ratio of New SA to Original SA
3	1	2	60.285	1
4	2	4		
5	3			
6	4			
7	5			

- Use spreadsheet formulas to complete the spreadsheet. Depending on your software, you may need to type “PI” or “PI()” for π . See your spreadsheet’s help feature if you need assistance.
- Compare the stretch factor for the radius to the ratio of the new surface area to the original surface area. What pattern do you notice?
- Use your pattern to predict the surface area of the sphere if you multiply the radius by 6. Extend your spreadsheet to check your answer.
- In your own words, express the relationship between a change in the radius of a sphere and the change in its surface area.

Create Connections

- Sketch an example of a composite object with dimensions in centimetres. Explain how you can find the surface area. Describe how you would convert your answer to an appropriate imperial unit of area.
- People communicate in different ways, such as orally, in writing, and even using sign language. In your own words, explain why the surface area of any object is expressed in square units.

Did You Know?

American Sign Language is the most commonly used form of sign language in North America.



2.3

Volume



Focus on ...

- solving problems involving the volume of three-dimensional objects
- finding an unknown dimension of a three-dimensional object given its volume

Western Canada is rich in natural resources. To make the most of Canada's natural resources, citizens need to understand the mathematics required to determine what they have, how to access it, and what it is worth. Whether it is recovering diamonds from Nunavut and the Northwest Territories or potash from Saskatchewan, transporting oil, or harvesting wood, measurement is a critical part of responsibly using Canada's resources. For many resources, volume is an important measurement: barrels of oil, board feet of lumber, and bushels of grain are just some of the traditional units of volume.

Materials

- conical cup
- paper
- scissors
- tape or glue
- sand, rice, or popcorn

Investigate Volume

What is the relationship between the volume of a right cone and the volume of a right cylinder?

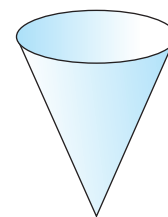

1. Using a right conical cup for reference, create a right cylinder with the same height and the same base area as the cone.
2. If you fill the cup with material (for example, rice, sand, or popcorn), predict how many cups of your material it will take to fill the cylinder.
3. Test your prediction.
4. **Reflect and Respond**
 - a) Discuss with a partner the results of your investigation.
 - b) Is there a relationship between the amount of material that the cone holds and the amount of material that the cylinder can hold? What is the relationship?

Link the Ideas

Volume of a Right Cone

The volume of a right prism or right cylinder can be found by multiplying the area of its base, B , by its height, h .

$$V = Bh$$

The volume of a right cone is related to the volume of a right cylinder with the same radius and height. The volume of the cone is one third of the volume of the cylinder.

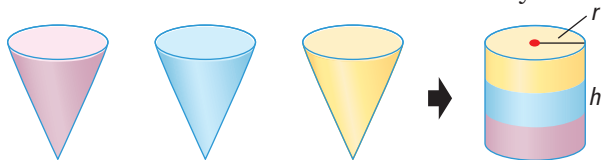

For a right cone with radius r and height h , $V_{\text{cone}} = \frac{1}{3}Bh$.

$$V_{\text{cone}} = \frac{1}{3}\pi r^2 h$$

Volume of a Right Pyramid

This relationship is also true for right rectangular prisms and right pyramids. The volume of a right pyramid is one third of the volume of a right prism with the same base and height.

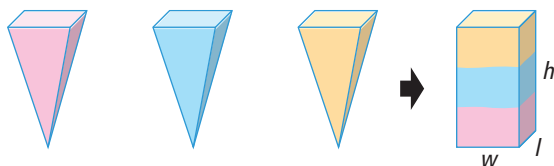

For a right pyramid with a rectangular base of length (l), width (w), and a perpendicular distance (h) from the base of the pyramid to its **apex**, $V_{\text{pyramid}} = \frac{1}{3}Bh$.

$$V_{\text{pyramid}} = \frac{1}{3}lwh$$

Volume of a Sphere

The volume of a sphere is two-thirds the volume of a cylinder with the same radius and a height equal to the diameter of the sphere. If the sphere has a radius r , then the cylinder has a base radius r and a height $2r$.

$$V_{\text{sphere}} = \frac{2}{3}(\text{volume of cylinder})$$

$$V_{\text{sphere}} = \frac{2}{3}\pi r^2 h$$

$$V_{\text{sphere}} = \frac{2}{3}\pi(r^2)(2r)$$

$$V_{\text{sphere}} = \frac{4}{3}\pi r^3$$

$$V_{\text{sphere}} = \frac{4}{3}\pi r^3$$

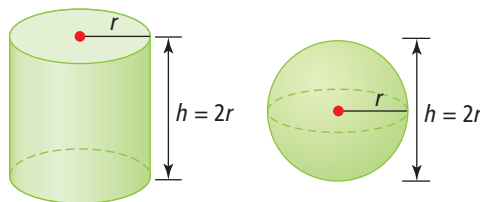

WWW Web Link

To watch a video showing the relationship between the volume of a right cone and the volume of a right cylinder, go to www.mhrmath10.ca and follow the links.

apex

- the highest point of a pyramid

Example 1 Calculate the Volume of a Right Cylinder and a Right Cone

- a) Calculate the volume of the right cylinder, to the nearest tenth of a cubic centimetre.
- b) Calculate the volume of the right cone, to the nearest tenth of a cubic centimetre.

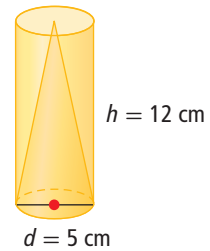

Solution

- a) For the cylinder,

$$\begin{aligned}r &= 5 \div 2 & h &= 12 \\ &= 2.5\end{aligned}$$

Substitute into the formula $V = \pi r^2 h$.

$$V = \pi r^2 h$$

$$V = \pi(2.5)^2(12)$$

$$V = 75\pi$$

$$V = 235.619\dots$$

The exact value is $75\pi \text{ cm}^3$; an approximate value is 235.6 cm^3 .

The volume of the cylinder is approximately 235.6 cm^3 .

- b) For the cone,

$$\begin{aligned}r &= 5 \div 2 & h &= 12 \\ &= 2.5\end{aligned}$$

Method 1: Use a Formula

Substitute into the formula $V = \frac{1}{3}\pi r^2 h$.

$$V = \frac{1}{3}\pi r^2 h$$

$$V = \frac{1}{3}\pi(2.5)^2(12)$$

$$V = 25\pi$$

$$V = 78.539\dots$$

The exact value is $25\pi \text{ cm}^3$, an approximate value is 78.5 cm^3 .

The volume of the cone is approximately 78.5 cm^3 .

Method 2: Use Volume Relationships

Since the volume of the cone is one third of the volume of the cylinder, you could divide the volume of the cylinder by three.

$$V = \frac{1}{3}(235.6)$$

$$V = 78.533\dots$$

The volume of the cone is approximately 78.5 cm^3 .

Your Turn

- a) What is the volume of the right cylinder, to the nearest cubic centimetre?
- b) What is the volume of the right cone, to the nearest cubic centimetre?

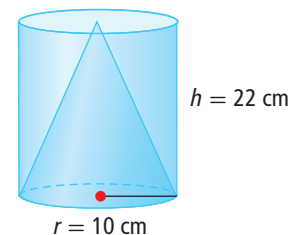

Example 2 Calculate the Volume of a Right Pyramid

Many of the operating costs of a greenhouse depend on its volume. For example, the energy used to heat a building depends on the volume of the building. The two large greenhouses at the Muttart Conservatory have square bases measuring 26 m on each side. The apex of each greenhouse is 24 m high. What is the volume of each greenhouse, to the nearest cubic metre?

Solution

Since the base is a square, $l = w = 26$, and $h = 24$.

Substitute into the formula $V = \frac{1}{3}lwh$.

$$V = \frac{1}{3}lwh$$

$$V = \frac{1}{3}(26)(26)(24)$$

$$V = 5408$$

The volume of each of the large greenhouses is 5408 m³.

Your Turn

- The Muttart Conservatory also has two smaller greenhouses. The base of each greenhouse is a square with side length 19.5 m, and the height of each greenhouse is 18 m. What is the volume of each of the smaller greenhouses?
- If the smaller greenhouse had been designed as a right rectangular prism with the same size base, what would its height have to be in order for the greenhouse to have the same volume?



Did You Know?

Archimedes is attributed with the discovery of the formula for finding the volume of a sphere. He is considered by most historians of mathematics as one of the greatest mathematicians of all time. Before his death, he requested that his tomb include a monument featuring a stone sphere and cylinder.



Example 3 Calculate an Unknown Dimension When Given a Volume

The volume of an exercise ball is approximately 4188.8 cm^3 . What is the diameter of this ball, in centimetres?

Solution

Substitute into the formula for the volume of a sphere.

$$\begin{aligned}V &= \frac{4}{3}\pi r^3 \\4188.8 &\approx \frac{4}{3}\pi r^3 \\3(4188.8) &\approx 3\left(\frac{4}{3}\pi r^3\right) \\12\,566.4 &\approx 4\pi r^3 \\ \frac{12\,566.4}{4\pi} &\approx \frac{4\pi r^3}{4\pi} \\1000 &\approx r^3 \\ \sqrt[3]{1000} &\approx \sqrt[3]{r^3} \\10 &\approx r\end{aligned}$$

The symbol $\sqrt[3]{}$ indicates the cube root of a number. $\sqrt[3]{1000} = 10$ because $10 \times 10 \times 10 = 1000$.

The radius is approximately 10 cm. Therefore, the diameter of the ball is approximately 20 cm.

Your Turn

- Find the cube root of 343.
- Find the diameter, correct to the nearest millimetre, of a sphere with volume $288\pi \text{ cm}^3$.

Example 4 Finding the Volume of Composite Figures

Esther is creating a clay sculpture that includes a sphere attached to a right cone. What volume of clay, in cubic centimetres, does she need to make the sculpture?

Solution

Volume of Sphere

$$V = \frac{4}{3}\pi r^3$$

$$V = \frac{4}{3}\pi(18)^3$$

$$V = 7776\pi$$

Volume of Cone

$$V = \frac{1}{3}\pi r^2 h$$

$$V = \frac{1}{3}\pi(5)^2(6)$$

$$V = 50\pi$$

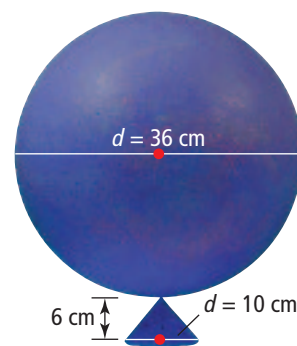

The diameter is twice the radius. The radius of the sphere is $\frac{36}{2}$ or 18 cm. The radius of the cone is $\frac{10}{2}$ or 5 cm.

Volume of Entire Sculpture

$$\begin{aligned}\text{total volume} &= \text{volume of sphere} + \text{volume of cone} \\ &= 7776\pi + 50\pi \\ &= 7826\pi\end{aligned}$$

The volume of the sculpture is $7826\pi \text{ cm}^3$, which is approximately $24\,586 \text{ cm}^3$.

Your Turn

The Dominion Astrophysical Observatory near Victoria, BC, has a cylindrical base with a diameter of 20.1 m and a height of 9.8 m. The dome is half a sphere with the same diameter as the cylindrical base. What is the volume of the observatory?



© National Research Council Canada

Key Ideas

- The volume of a right cone is found by calculating one third of the volume of its related right cylinder.

$$V_{\text{cone}} = \frac{1}{3}\pi r^2 h$$

- The volume of a right pyramid is found by calculating one third of the volume of its related right prism.

$$V_{\text{pyramid}} = \frac{1}{3}lwh$$

- The volume of a sphere is found by using the formula

$$V_{\text{sphere}} = \frac{4}{3}\pi r^3$$

- If you know the volume of an object, you can calculate an unknown dimension.

The volume of the right pyramid with square base is 384 ft^3 . Find the dimensions of the base.

$$V = \frac{1}{3}Bh$$

$$384 = \frac{1}{3}w^2(8)$$

$$3(384) = 3\left(\frac{1}{3}w^2(8)\right)$$

$$1152 = w^2(8)$$

$$\frac{1152}{8} = w^2$$

$$144 = w^2$$

$$12 = w$$

The dimensions of the base are $12 \text{ ft} \times 12 \text{ ft}$.

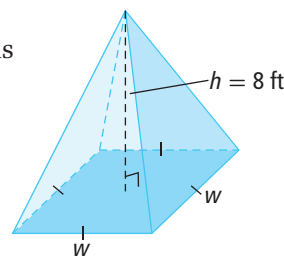

Check Your Understanding

Practise

Where necessary, express your answers to the nearest tenth of a unit.

1. Calculate the volume of each of the following.

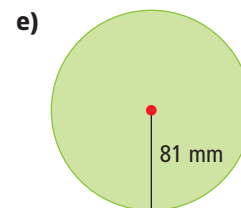
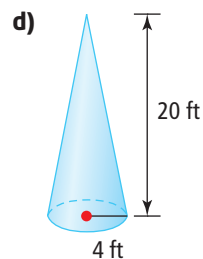
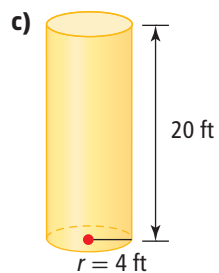
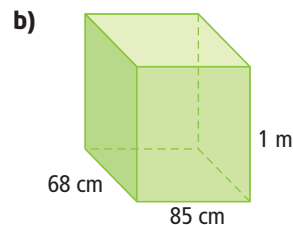
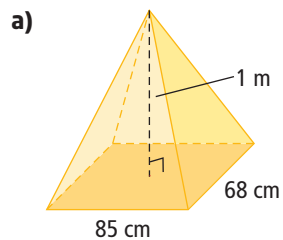

2. Calculate the volume of each solid.

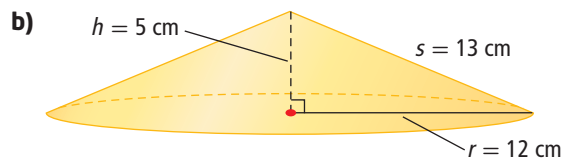
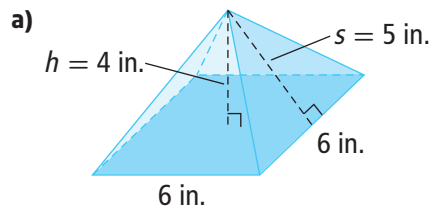

3. Calculate the volume of the following composite object, in cubic metres.

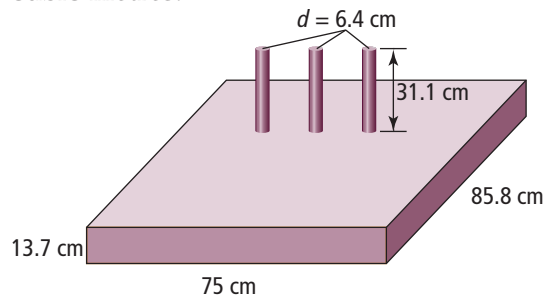

4. Erin and Janine were asked to find the volume of this composite figure. Their work is shown.

Erin

$$V = \frac{1}{3}\pi r^2 h + \pi r^2 h$$

$$V = \frac{1}{3}\pi(3^2)(22) + \pi(3^2)(22)$$

$$V = \frac{1}{3}198\pi + 198\pi$$

$$V = 66\pi + 198\pi$$

$$V = 264\pi$$

$$V \approx 829.38$$

The volume is 829.38 in.^3

Janine

$$V = \frac{1}{3}(\pi r^2 h + \pi r^2 h)$$

$$V = \frac{1}{3}(\pi(3^2)(22) + \pi(3^2)(22))$$

$$V = \frac{1}{3}(198\pi + 198\pi)$$

$$V = \frac{1}{3}(396\pi)$$

$$V = 132\pi$$

$$V \approx 414.69$$

The volume is 414.69 in.^3

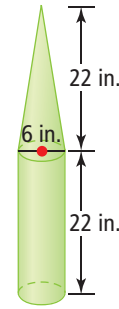

Alliance Pipeline

- a) Discuss with a partner which student correctly calculated the volume. Justify your answer.
 b) Identify which method you would use to calculate the volume of the composite figure.

5. Calculate the missing dimension for each of the following.

a) $V = 161.6 \text{ cm}^3$

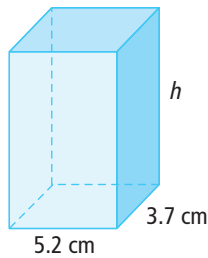

b) $V = 196 \text{ in.}^3$

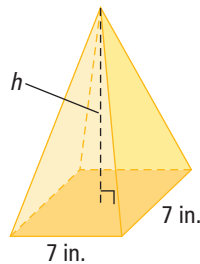

c) $V = 339.3 \text{ cm}^3$

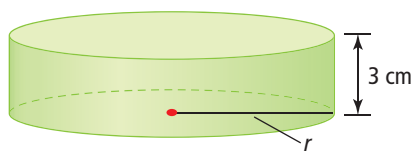

d) $V = 8.1 \text{ yd}^3$

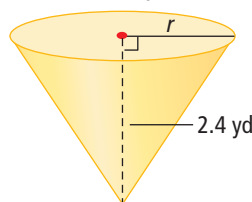

Apply

6. The Alliance Pipeline begins in northeastern British Columbia and is 3017 km long. It is the longest pipeline in North America. It carries crude oil, as well as natural gas, from exploration sites to markets. One of the longest sections of the pipeline is 1221.73 km long, with a diameter of 914 mm. The pipeline does not always run in a straight line. If it was straightened, what is the maximum volume of oil that can be contained in this section of pipeline? Express your answer to the nearest hundredth of a cubic metre.

Did You Know?

Jade is the official gemstone of British Columbia. It is found in large deposits in the Lillooet and Cassiar regions. Its translucent emerald-green appearance makes it a popular choice for jewellery and other tourism memorabilia.

7. A right rectangular prism measures 9 in. \times 4 in. \times 6 in. What would be the dimensions of a cube with the same volume?
8. Kendra wants to purchase a bead necklace made of jade. The cost of the necklace depends upon the amount of jade in the necklace. Each bead is 7 mm in diameter and there are 100 beads in the necklace. What is the amount of jade in the necklace, in cubic centimetres?



9. In her art class, Andrea wants to make a locking puzzle in the shape of a pyramid to have on her desk. The base will measure 6 cm by 8 cm, and the height will be 10 cm. Calculate the amount of wood needed to create the pyramid.

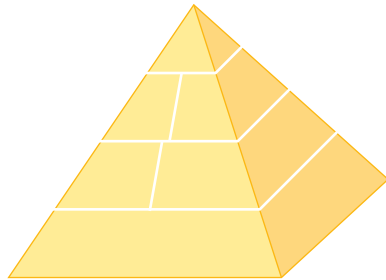

10. For each of the following objects, the volume is given. Sketch the object and calculate the unknown dimension.
- A right cylinder has a volume of 500 cm^3 and a height of 16 cm. Calculate its radius.
 - A right cone with a volume of 20 cm^3 has a diameter of 5 cm. Calculate its height.
 - A sphere has a volume of 48 cm^3 . Calculate the radius.

11. Traditionally, the Inuit of northwestern Canada have built domed-shaped family homes called igloos. The volume of snow in an igloo varies depending on the size. Every igloo has a ventilation opening as well as an entrance.

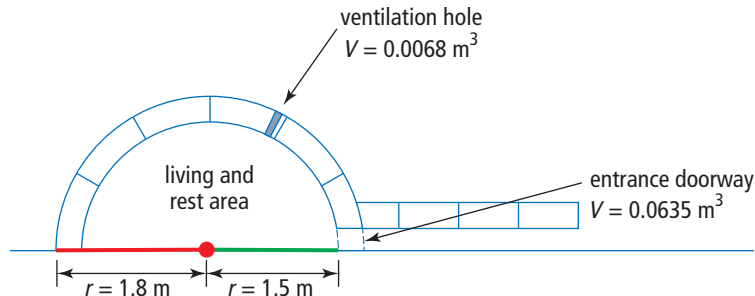

Calculate the volume of snow used to construct the main portion of igloo in the picture, not including the entrance tunnel. Express your answer to the nearest tenth of a cubic metre.

12. The roof of a house is shaped like a right pyramid with a square base. The base of the pyramid measures 32 ft on each side, and the roof must enclose a volume of at least 4096 ft^3 of air. Calculate the minimum height for the apex of the roof.

13. Grady has designed a wooden storage cabinet for his CDs and DVDs. The cabinet has a wooden door that can be closed. The cabinet is a right rectangular prism, as shown.

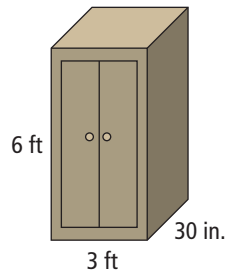

- Calculate the volume of the cabinet.
- Grady is concerned that the cabinet is too big for his room. He considers keeping the length and width the same, but reducing the height by one quarter. Estimate the volume of the modified cabinet.
- Calculate the volume of the cabinet in part b). Was your estimate accurate? Explain how changing one dimension of a right rectangular prism by a factor of k will change the volume of the prism.

14. International Games are being held in your community. Your promotions committee designed a souvenir consisting of a cube with an inserted sphere representing the Earth. Both pieces are constructed from solid crystal. The sphere replaces one quarter of the volume of the cube. Calculate the volume of the souvenir piece.

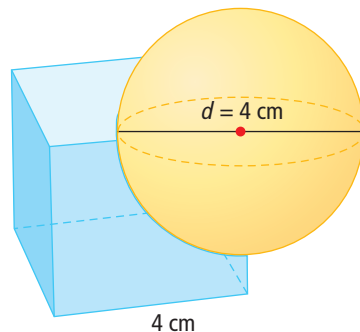

Did You Know?

The word *igloo*, meaning a house of snow. The igloo shape is semi-spherical because it creates the greatest amount of living space with the least amount of snow.

Did You Know?

The first cellular phones to be created were very large and bulky. The first cell phone came to the market in 1984 from Motorola and weighed 2 lb. It was a DynaTac 8000X and it sold for \$3995.

WWW Web Link

To view a video that describes the cell phone development by Motorola, go to www.mhrmath10.ca and follow the links.

15. **(Unit Project)** The first cell phones were much larger than present-day cell phones. A typical cell phone now has a volume between 4 in.^3 and 6 in.^3 . Using the information shown in the photo, estimate the volume of the first commercial portable cell phone released in 1984 by Motorola.



16. **(Unit Project)** An MP3 player with a memory of 80 GB has a storage capacity of 20 000 average-length songs. A vinyl LP record is 0.11 in. thick and on average can hold 12 songs. If the dimensions of the MP3 player are 4.14 cm wide, 9.15 cm high, and 0.85 cm thick, and the record has a radius 6 in., how many songs per cubic centimetre are there on each storage medium? Express your answers to the nearest hundredth.

Extend

For each of the following, express your answers to the nearest tenth of a unit where necessary.

17. Through your work with volume, you discovered a relationship between the right cone and the right cylinder. Extend your work to describe a relationship between a right cone and a sphere.
18. Kelly works at an ice cream shop. Customers can choose to have a cone that is lined with chocolate. The store buys the chocolate-lined cones, but the owners are wondering if they could save money by lining their own cones. To decide, they ask Kelly to calculate the amount of chocolate used to coat the inside of each cone with a layer of chocolate 1 mm thick. Each cone has an inside diameter of 5.5 cm and a slant height of 13 cm. Calculate the volume of chocolate used to line the inside of each cone.



19. Use spreadsheet software to help investigate how changing the radius of a sphere changes its volume. Create a spreadsheet like the one shown below.

	A	B	C	D
1	Investigating Changes in Dimensions of a Sphere			
2	Stretch Factor	Radius	Volume	Ratio of New Volume to Original Volume
3	1	3	113.1	1
4	2	6		
5	3			
6	4			
7	5			

- a) Use spreadsheet formulas to complete the spreadsheet. Depending on your software, you may need to type “PI” or “PI()” for π . See your spreadsheet’s help feature if you need assistance.
- b) Compare the stretch factor for the radius to the ratio of the new volume to the original volume. What pattern do you notice?
- c) Use your pattern to predict the volume of the sphere if you multiply the radius by 6. Extend your spreadsheet to check your answer.
- d) In your own words, express the relationship between a change in the radius of a sphere and its volume.
20. Choose another solid that you have studied in this section. Create a table to investigate how the volume of the solid is affected by changing one of the dimensions of the solid.

Create Connections

21. **(Unit Project)** Work individually or in a small group. Choose a 3-D object related to your Unit 1 project.
- a) Estimate its volume in both SI and imperial units. Are your estimates reasonable? Explain.
- b) Calculate the volume. Are the units in your answer appropriate for the object?
- c) In which measurement system was your estimate more accurate? Why do you think this happened?



2 Review

2.1 Units of Area and Volume, pages 56–65

Where necessary, express your answers to the nearest hundredth of a unit.

1. Calculate each area using the indicated unit.

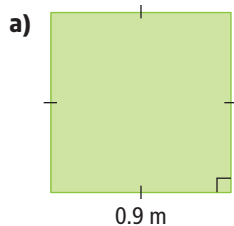

$$A = \blacksquare \text{ cm}^2$$

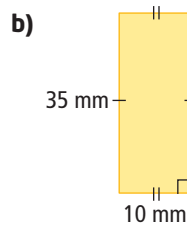

$$A = \blacksquare \text{ in.}^2$$

2. Calculate each volume using the indicated unit.

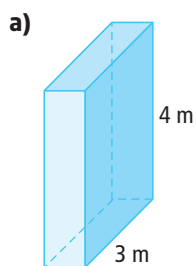

$$V = \blacksquare \text{ ft}^3$$

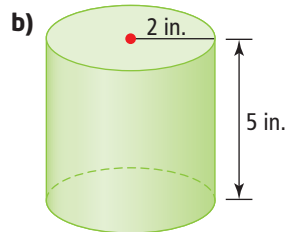

$$V = \blacksquare \text{ cm}^3$$

3. Describe personal referents that you could use to remember what 1 cm^2 , 1 in.^2 , and 1 m^2 looks like. Compare your personal referents to those of a classmate.
4. Justin, a landscaper, is fertilizing a new lawn. The directions on the fertilizer are to apply 6 lb of fertilizer per 1000 ft^2 . Justin knows that the lawn he is fertilizing has an area of 400 m^2 . How much fertilizer should Justin apply to the lawn?

2.2 Surface Area, pages 66–79

Where necessary, express your answers to the nearest hundredth of a unit.

5. Sketch each of the following and calculate the surface area.
- A cone has radius 15.5 cm and slant height 26.2 cm.
 - A cone has slant height 24 in. and diameter 16 in.
 - A pyramid has a square base with sides 44 cm and slant height 64 cm.
 - A sphere has diameter 3.0 cm.

6. Calculate the missing dimension in each of the following.
- A right cone has surface area 12 m^2 and radius 1.3 m .
 - The square base of a right pyramid has area 2304 cm^2 and surface area 6144 cm^2 .
 - A sphere has surface area 385 cm^2 .
7. Carsyn's vehicle has a spare tire that is bolted to the outside of the vehicle. To protect the spare tire, she wants to make or buy a protective cover that she can slip over the tire. The tire has a diameter of 820 mm and a depth of 235 mm . Calculate the minimum amount of material needed to make the cover to the nearest square metre. What assumptions did you make?
8. Kale needs to build a new house for his dog. After researching, he has learned that the width and the length of the doghouse should be about 125% of the length of his dog, and 130% of the height of his dog's head.
- Kale's dog is 40 in. long and 28 in. tall. What dimensions should Kale use to make the doghouse if it is a right prism with a square base?
 - What size do you recommend Kale make the doorway? Explain your reasoning.
 - Kale realizes that a flat roof is not a good idea for his doghouse. He decides to build a pyramidal roof for the house instead. By experimenting, he decides that the roof will have a slant height of 30 in. Draw a sketch of the doghouse and label all dimensions.
 - Calculate the total surface area of Kale's doghouse, with the roof.
9. The radius of Earth is $6\,370\,000 \text{ m}$. Canada has a land area of $9\,003\,507 \text{ km}^2$. What percent of Earth's surface does Canada represent?



2.3 Volume, pages 80–91

Where necessary, express your answers to the nearest hundredth of a unit.

10. Calculate the volume of each of the following.
- A cylinder has radius 15 ft and height equal to its diameter.
 - A cone has height 14 cm and diameter 4.5 cm .
 - A rectangular pyramid has base 12 ft by 14 ft and height 18 ft .
 - A sphere of radius 4.1 cm .

11. Calculate the missing dimension in each of the following.
- A cylinder has volume 1 m^3 and height 0.6 m .
 - A cone has radius 40 cm and volume 7800 cm^3 .
 - A square-based pyramid has height 92 cm and volume 5.4 m^3 .
 - A sphere has volume 2469 cm^3 .

12. Many grain terminals are cylindrical in shape. This one is near Carseland, AB. The height of the terminal is 40 m , and the inside diameter of each grain storage tower is 11.7 m .



- What is the storage capacity of each tower, to the nearest cubic metre?
- If a small grain truck has a rectangular box measuring 5 m by 1.5 m by 2.4 m , how many truckloads of grain can one tower hold?

13. When a concrete structure is built, an engineer often performs a slump test on the concrete to ensure that it is of suitable strength and consistency. The engineer fills a truncated cone with bottom diameter 200 mm , top diameter 100 mm , and height 300 mm with concrete. The engineer then places the cone on the ground and lifts off the cone. After a period of time, she measures the amount that the top of the cone has slumped to decide if the concrete is appropriate.

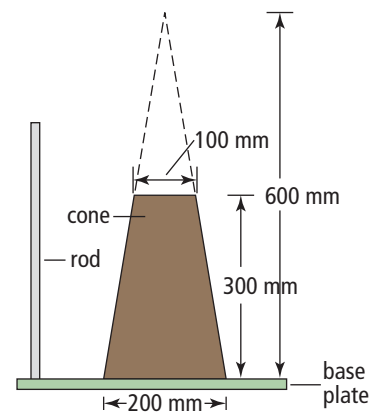

- The original cone from which the slump-test cone was derived had a height of 600 mm . What was the volume of the original cone? Express your answer to the nearest cubic millimetre.
- What is the volume of the slump-test cone? Express your answer to the nearest cubic millimetre.

2 Practice Test

Multiple Choice

For #1 to #5, choose the best answer.

1. Fertilizer application instructions say to apply 0.5 L of fertilizer per 100 m^2 . Zack knows that his lawn has dimensions of 15 m by 20 m. How many litres of fertilizer will Zack require?

A 1.5 L **B** 4.5 L **C** 5.7 L **D** 6.8 L

2. A cake-decorating bag has the shape of a cone. To the nearest cubic centimetre, how much frosting will fit into a cake-decorating bag that has a diameter of 15 cm and a height of 30 cm?

A 1767 cm^3 **B** 5301 cm^3
C 7068 cm^3 **D** $21\,206 \text{ cm}^3$

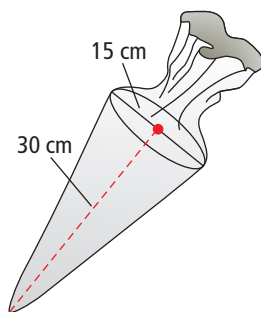

3. An official major league baseball has a diameter of 7.4 cm. Correct to the nearest tenth of a unit, the amount of leather needed to cover the ball is

A 1697.4 cm^2 **B** 688.1 cm^2 **C** 212.2 cm^2 **D** 172.0 cm^2

4. A magnetic paperweight has the shape of a right pyramid with slant height 8.5 cm. The square base of the pyramid has side length 10 cm. The surface area of the pyramid is

A 270 cm^2 **B** 283 cm^2
C 440 cm^2 **D** 850 cm^2

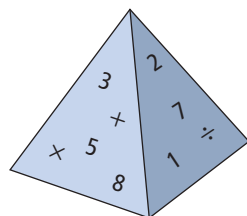

5. A drink manufacturer is designing the can for a new type of drink. The can is to have a capacity of between 250 mL and 285 mL. The height of the can is set at 14 cm. If 1 mL is equivalent to 1 cm^3 , what range of values is possible for the diameter of the can?

A 2.4 cm to 2.5 cm **B** 4.8 cm to 5.0 cm
C 7.5 cm to 7.9 cm **D** 15.0 cm to 15.9 cm

Short Answer

6. Calculate the volume and surface area of a sphere with diameter 28 cm. Express your answers to the nearest whole unit.
7. A right conical paper cup has a height of 65 mm and a diameter of 38 mm. Calculate the volume of the cup. Express your answer to the nearest tenth of a cubic millimetre.

8. The Yukon Quest is an annual dogsled race between Whitehorse, YT and Fairbanks, Alaska. The race distance is 1645 km. Racers must have between 8 and 14 dogs for this challenging race. Many racers have built kennels to transport the dogs to the race. One competitor has built a trailer that is a right rectangular prism measuring 2 m wide by 1.6 m high by 3.2 m long. He has divided this trailer into 16 identical kennels for his dog team, as shown in the diagram. How much material is needed to build the kennels?

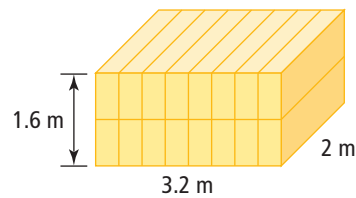

9. A theatre owner has two different right cylindrical popcorn containers. One is 18 cm high with a diameter of 14 cm, and the other is 16 cm high with a diameter of 16 cm. Which container should be for a small order of popcorn, and which should be the large? Justify your answer.

Extended Response

10. You have 500 cm^2 of material available to cover different shapes. What is the maximum volume of each object that you can make with this amount of material?

- a)** a cube **b)** a sphere

11. A tennis ball has a diameter of $2\frac{9}{16}$ in. A manufacturer packages three tennis balls stacked on top of one another in right cylindrical cans. Sketch the tennis ball container. Label the diameter and height of the container. What are the volume and surface area of the container?

12. Canada is one of the top three producers of diamonds worldwide. Most of these diamonds are mined in Nunavut and the Northwest Territories. Diamonds are recovered from kimberlite pipes, long narrow regions beneath Earth's surface.

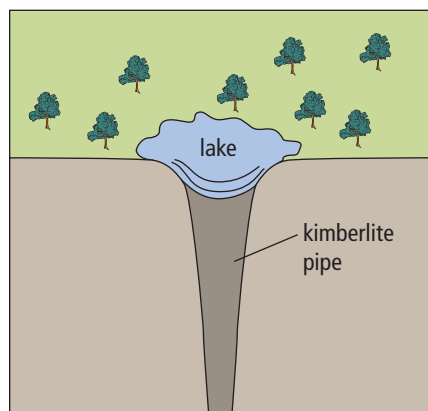

One kimberlite deposit has an area of $50\,000 \text{ m}^2$ at ground level and a depth of 2 km . Estimate the volume of the kimberlite deposit. What assumptions did you make?

13. A recycling depot in Yellowknife has a machine that bales the recycled goods into bales measuring 5 ft by 4 ft by 3 ft .

- a)** A new machine is being considered that will make right cylindrical bales. If the bales contain the same amount of material as the original ones and have a height of 5 ft , what is their diameter?
- b)** Which type of bale has the smaller surface area? Justify your answer.