

Name: _____

Date: _____

Foundations of Math 10 LG 15 Ver B

/20

1. A right triangle has one side measuring 9 cm. The length of the hypotenuse is 14 cm. Draw a diagram of the triangle and calculate the length of the missing side to two decimals. (2 marks)

2. Determine the length of x in the triangle below to the nearest tenth of a metre. (3 marks)

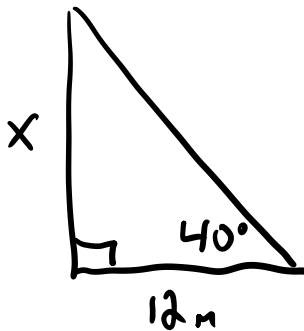

3. Kelly is flying a kite in a field. If his kite is 40 m above the ground and makes an angle of 72° with the ground, how long is the kite string to the nearest tenth of a metre? (3 marks)

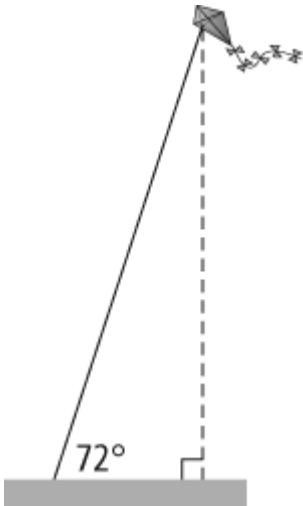

4. In $\triangle XYZ$, XY and XZ have equal lengths of 7 cm. The base of the triangle, YZ , is 12 cm. Using trigonometry, determine the measure of angle, Y , to the nearest hundredth of a degree. (3 marks)

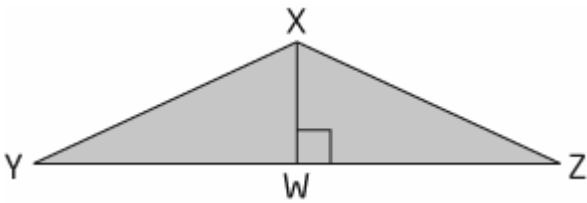

5. Matthew parks his car between Karen's and Patrick's apartment buildings. The car is 46 m in front of Karen's apartment building. The angle of elevation from the car to the top of the building is 40° . Matthew's car is 39 m away from Patrick's apartment building. The angle of elevation from the car to the top of the building is 50° .

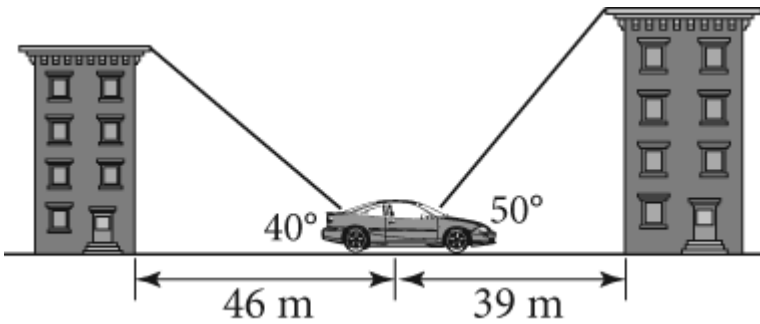

- a) Determine the height of each building, to the nearest metre. (3 marks)

- b) State which building is taller, and by how much. (1 mark)

6. A cell phone tower is supported by two guy wires, attached on opposite sides of the tower. One guy wire is attached to the top of the base of the tower at point A. The other is attached to the base at point E, at a height of 70 m above the ground.

a) Find the measure of angle E in degrees. (1 mark)

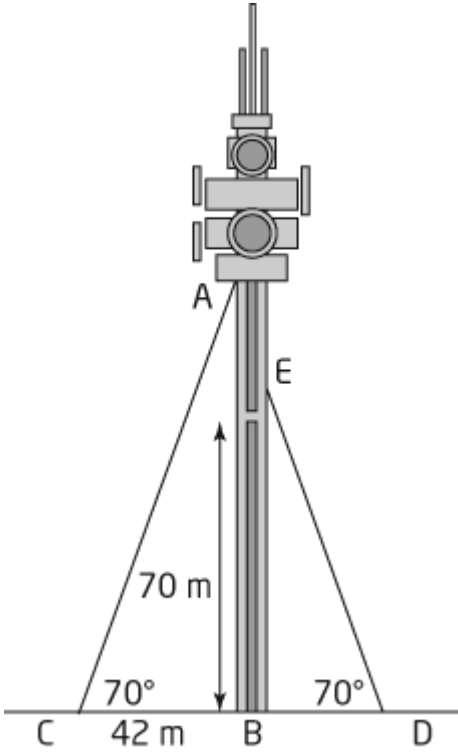

b) Determine the height of the base of the tower (AB), to the nearest metre. (2 marks)

c) Determine the length of each guy-wire (AC and DE), to the nearest metre. (2 marks)